



Hangcha Europe GmbH

Mariechen-Graulich-Straße 12a,
65439 Flörsheim am Main,
Germany

Administration
Tel: 0049-61453769188
E-mail: admin@hangchaeurope.com

Sales Management
Thomas Dittrich
Mob: 0049-16096548808
E-mail: thomas.dittrich@hangchaeurope.com

Technical Support
Thomas Pannke
Mob: 0049-01759284213
E-mail: thomas.pannke@hangchaeurope.com

www.hangchaeurope.com



Folgen Sie uns auf
Instagram



Folgen Sie uns auf
Facebook



Folgen Sie uns auf
YouTube



"Hangcha Forklift"
App herunterladen



ISO14001
ISO14001:2015



ISO9001
ISO9001:2015



HANGCHA trucks conform
to the European Safety
Requirements.

2023 VERSION 1/COPYRIGHT 2023/06

HANGCHA Group Co., LTD behält sich das Recht vor, Änderungen bezgl. Farbe, Spezifikationen, Ausstattung und sonstige Details, dierer Bröschüre ohne Vorankündigung vorzunehmen. Fahrzeugfarben können von den Farben in dieser Brochure abweichen.



A Series Stand-on Reach Truck

with capacities of 2,000 to 2,500kg

The World of Hangcha
SINCE 1956



LET THE LI-ION POWER BE FREE



INNOVATIVE SOLUTIONS NEW POWER NOW

Innovative, reliable lithium-ion technology (Lithium Iron-Phosphate), which are developed jointly by HANGCHA and CATL. Battery cells and modules are from CATL, with reliable quality, exclusively for HANGCHA.

- / We use square lithium iron phosphate batteries and modules used in large quantities by commercial vehicles in mature economies.
- / The module uses an aluminum alloy frame which is sturdy, lightweight and with excellent heat dissipation.
- / Safe and effective: Charging efficiency as high as 98%, thermal runaway temperature 600 °C or above.
- / Adapted to low temperatures: Comes standard with an electrical heating feature, ensuring normal operation in low temperatures.
- / Quick charging.
- / Long-working: 4000 charging cycles, capacity retention greater than 80%.
- / Maintenance-free: Battery does not require manual maintenance.
- / Green and clean: Pollution-free, zero emissions.

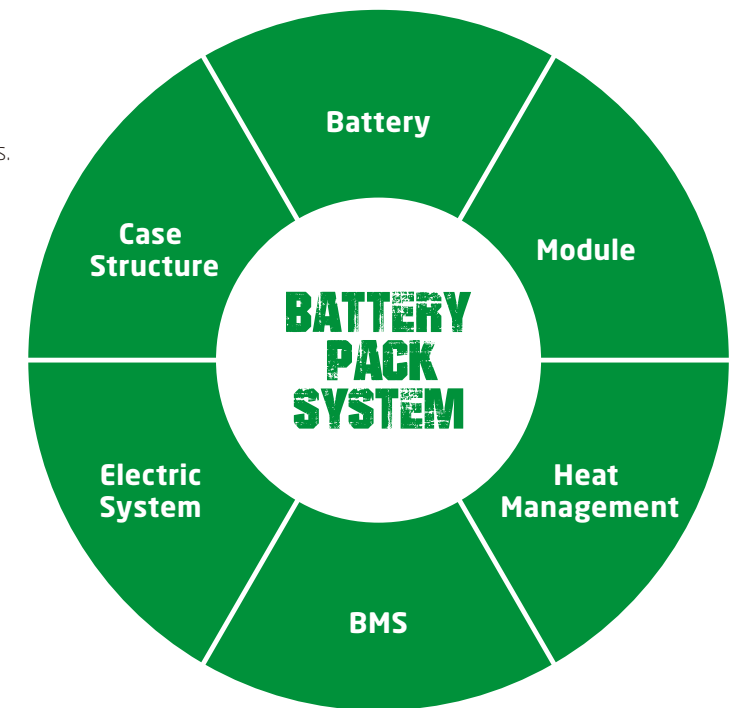

Rapid charging and opportunity charging ensure continuous availability of vehicles.

Li-ion powered forklifts are always available. They allow for fast full charging or boost charging. They are maintenance free and do not require a battery change when used for multi-shift operations.



HANGCHA provides Li-Ion battery (LiFePO4) with 5 years or 10000 hours warranty.

**5 YEARS
WARRANTY**

Li-Ion Battery Specification

Type		CQD20-AC55-1*	CQD25-AC55-1*
Battery voltage, capacity	V/Ah	48/302	48/302
Titans charger		SLC-48100	SLC-48100

Note: * CE model

A Series Stand-on Reach Truck

The new A series 2.0-2.5t standing driving forward-moving type is a new product developed by the company for different market needs.

The ergonomically-designed comfortable vehicle has wide operating vision and a stable control system, and is further optimized and improved in terms of configuration, parameter, performance, safety, cost, etc., making this product comparable to foreign brands and have obvious advantages when compared with other similar domestic products.

**Environment/
Efficiency/
Economy**



Comfort

- / Optimized ergonomic design shows the steering wheel, joystick and accelerator to the driver at the best distance, making the driving operations easier and more comfortable.
- / The newly-designed molded broad backrest is soft and comfortable, reducing operator fatigue.
- / Shimadzu's low-power multiway valve reduces operating force and improves comfort by 30%.
- / A new layout provides a larger operation space. The low pedals enable the operator to get on and off the vehicle more easily.
- / The imported LORD sensor enables high safety and makes operations to be adapted to road conditions.

Energy saving and high efficient

- / With equipment rationally arranged on the premise that the strength meets the requirements, the vehicle has less weight and cost and less energy consumption.
- / The hydraulic system is optimized to improve the lifting performance. The no-load lifting performance is increased by 23%, and the full-load lifting performance is increased by 22%.
- / The drive system uses a high speed ratio gearbox to make the motor require higher speed and less torque.
- / The combined LED lights (headlights + turn signal lights) have high brightness and low energy consumption.

Stability

- / Suspension control system effectively reduces the shake when turning, lifting and moving forward and backward.
- / The pump motor assembling on the rear side of the body makes the center of gravity moving backwards and improving stability.
- / Automatic speed control: Travel speed is controlled according to the lift height, providing stability and safety.

Maintenance

- / AC drive and lifting systems with maintenance-free motors are used.
- / AC steering with a maintenance-free motor is provided.
- / The fully open door enables easy repair and maintenance.
- / The controller and multiway valve are provided on the front side of the vehicle body. Only the front sealing plate needs to be opened for maintenance.



Operator's compartment



Safe pedal: when the pedal is released, traveling is stopped, and only hydraulic operation is enabled



Charging plug inside operator's compartment, this eliminates the need to disconnect the plug from battery, enhancing ease of operation (Std.)



New designed mast and the large open steel roof provide super visibility and safety



Forks can tilt forward/backward for easy loading

Safety

- / An optimal four-link suspension mechanism forces the drive wheel and the auxiliary wheels, thereby reducing slipping of the drive wheel.
- / A disc mechanical brake and regenerative braking system make the truck safer and more reliable.
- / Turn speed is controlled to the turning radius, providing stable turning matched to the state of operation.
- / If the operator is not in the normal operating position, travel power is interrupted and load-handling (except lowering) operations are stopped.
- / The right leg of the OHG moves backwards to protect the driver's back in case of a collision.

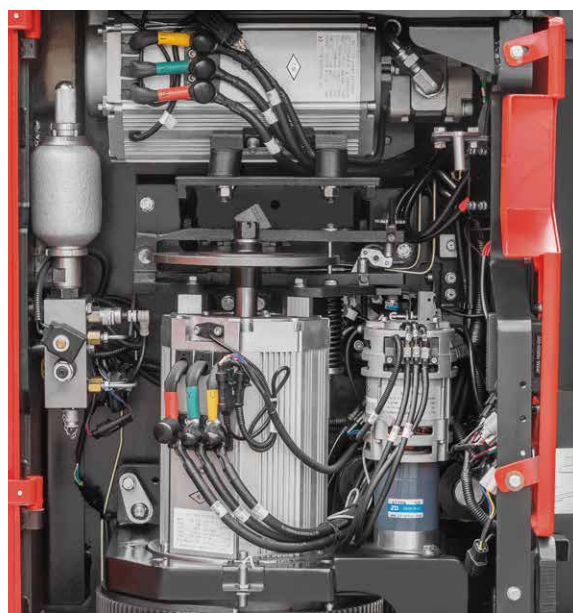

The loading wheels with hydraulic braking make the braking distance shorter and safer



Standard Specification

- / Headlights (LED) + turn signal lights (LED) + alarm lights (LED)
- / Shimadzu's standard triple valve
- / AC driving (5kw) + AC lifting (11kw)
- / Electric steering system (AC 670W motor)
- / Fork descending buffering (cylinder buffering)
- / Suspension control system
- / Automatic turning deceleration
- / Side charge
- / Mechanical brake
- / Regenerative braking (reversing, neutral, braking)
- / Interlock switch
- / In-place switch
- / Standard battery configuration: 48/325Ah
- / USB charging port
- / Hydraulic braking (loading wheels)

Options

- / Blue lights, straight projection lights
- / Optional quadruple and quintuple (Shimadzu)
- / Skid control system
- / Fork camera
- / Altimeter
- / Code lock
- / Retroreflector
- / Fire extinguisher
- / Maximum battery capacity: 450Ah
- / Ascending buffering
- / Height selection
- / Descending locking valve
- / Side shift
- / Cigarette lighter
- / Smart module
- / Drive-in overhead guard

CQD20/25-AC55					
	Tianneng	Zibo	Xunqi	Hawker	FAAM
325 Ah	●	○	○	○	○
375 Ah	○	○		○	○
450 Ah	○				

● Std. ○ Opt.



COMFORTABLE DESIGN

It's convenient for getting on/off.



Floor height: 285mm.

Optimal lifting system

- / New optimal manufacturing process ensures the roller gap of the mast, making the mast sways smaller and the vehicle safer.
- / Add 2 safety functions: the mast moves backward to enable hydraulic buffer protection and reduce the speed in this position. It helps reduce the mast swaying when in a high position and makes the vehicle safer.
- / The optimized mast piping with an upper and lower layout mast improves vision of the mast (Triplex mast).
- / The forklift's sleeve structure boasts a simple structure, small mast thickness and light weight.



BATTERY REACH OUT SYSTEM

The battery can be reached out easily. It enables smooth battery maintenance, inspection and replacement.

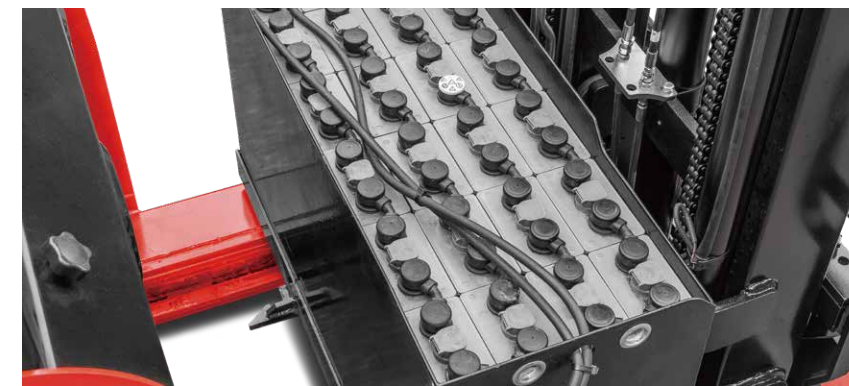

Battery removal

- 1 Step on the unlocking pedal
- 2 Press the safety switch
- 3 Mast moves operating lever forward

BATTERY REPLACEMENT OPERATION PROCESS

Battery insertion

- 2 Press the safety switch
- 3 Mast moves operating lever backward

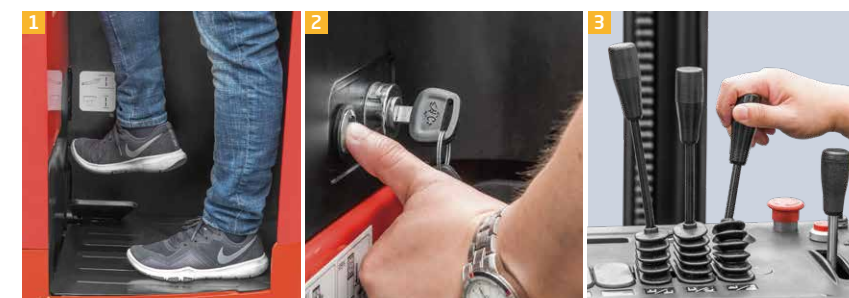

A series stand on reach truck 2.0-2.5t specification

Distinguishing mark	1.1	Manufacturer	HANGCHA GROUP CO.,LTD.		
	1.2	Manufacturer's type designation	CQD20-AC55*	CQD25-AC55*	
	1.3	Drive: electric (battery or mains), diesel, petrol, fuel gas	Electric	Electric	
	1.4	Operator Position	Stand On	Stand On	
	1.5	Rated capacity/rated load	Q (kg)	2000	2500
	1.6	Load centre distance	c (mm)	500	500
	1.7	Load distance, centre of drive axle to fork	x (mm)	485	610
	1.8	Load distance, centre of drive axle to fork,mast reached forward	x1 (mm)	180	180
	1.9	Wheelbase	y (mm)	1500	1700
Weight	2.1	Service weight (including battery)	Kg	2730	2760
	Tyres, chassis	3.1	Tyres: solid rubber, superelastic, pneumatic, polyurethane		Polyurethane
3.2		Tyre size, rear	mm	Ø343×135	Ø343×135
3.3		Tyre size, front ×2	mm	Ø250×120	Ø250×120
3.4		Tyre size,Caster ×2	mm	Ø150×85	Ø150×85
3.5		Wheels,number front/rear(×=driven wheels)		2/1×+2	2/1×+2
3.6		Tread width,front	b11(mm)	1074	1074
3.7		Tread width,rear	b12(mm)	685	685
Dimensions	4.1	Tilt of mast/fork carriage forward/backward	α/β(°)	3/5	3/5
	4.2	Height, mast lowered	h1 (mm)	2045	2045
	4.3	Lift	h3 (mm)	3000	3000
	4.4	Mast Extended height	h4 (mm)	3876	3876
	4.5	Free lift	h2(mm)	105	105
	4.6	Height of overhead guard	h6 (mm)	2245	2245
	4.7	Ground clearance,below mast	m2 (mm)	80	80
	4.8	Height of support arms	h8 (mm)	275	275
	4.9	Overall length	l1 (mm)	2180	2255
	4.10	Length to face of forks	l2 (mm)	1260	1335
	4.11	Overall width	b1/b2(mm)	1194/1190	1194/1190
	4.12	Fork dimensions ISO	s/e/l (mm)	40×122×920	40×122×920
	4.13	Distance between fork-arms	b4/b5 (mm)	278-784	278-784
	4.14	Reach distance	l4 (mm)	665	790
	4.15	Aisle width for pallets 1100 x 1100 , clearance 200	Ast (mm)	2775	2880
	4.16	Aisle width for pallets 1000 x 1200 crossways,clearance 200	Ast (mm)	2740	2860
	4.17	Turning radius	Wa (mm)	1755	1950
Performance Data	5.1	Travel speed,laden/unladen	Km/h	10.5/10.5	10.5/10.5
	5.2	Lift speed,laden/unladen	m/s	0.320/0.530	0.280/0.510
	5.3	Lowering speed,laden/unladen	m/s	0.450/0.400	0.450/0.400
	5.4	Reach speed,laden/unladen	m/s	0.110/0.110	0.110/0.110
	5.5	Max. gradeability,laden/unladen	%	10/15	10/15
Electric-engine	6.1	Drive motor rating S2 60 min	kW	AC 5	AC 5
	6.2	Lift motor rating at S3 15%	kW	AC 11	AC 11
	6.3	Steering motor	kW	AC 0.67	AC 0.67
	6.4	Battery voltage, nominal capacity K5	V/Ah	48/325	48/325
	6.5	Battery weight	kg	500	500
Addition data	7.1	Type of drive control		CURTIS Full AC	CURTIS Full AC
	7.2	Operating pressure for attachments	bar	140	140
	7.3	Sound level at the driver's ear according to EN / DIN 12 053	dB (A)	< 75	< 75

Note: * CE model

2.0~2.5t Mast Specification

Type	Model	Lifting height h3	Mast lowered h1	Mast extended h4		Free lifting height h2		Tilting range		Load capacity center at 500mm		
				With backrest	With backrest	With backrest	With backrest	Forward	Backward	2.0t	2.5t	
		mm	mm	mm	mm	mm	mm	(°)	(°)	kg	kg	
Wide view duplex mast	QA225M	2500	1795	3376	105	2000	3	5	2000	2500	2000	2500
		2700	1895	3576	105	2000	3	5	2000	2500	2000	2500
		3000	2045	3876	105	2000	3	5	2000	2500	2000	2500
		3500	2295	4376	105	2000	3	5	2000	2500	2000	2500
		4000	2645	4876	105	2000	3	5	2000	2500	2000	2500
		4300	2795	5176	105	2000	3	5	2000	2400	1800	2300
		4500	2895	5376	105	1900	3	5	2000	2400	1800	2300
		5000	3145	5876	105	1800	3	5	1800	2300	1800	2300
		4300	2040	5176	1164	2000	3	5	2000	2400	2000	2400
		4500	2105	5376	1229	2000	3	5	1900	2400	1900	2400
Full free triplex mast	QA225N	5000	2265	5876	1389	1800	3	5	1800	2300	1800	2300
		5500	2445	6376	1569	1500	3	5	1500	2150	1500	2150
		6000	2615	6876	1739	1400	3	5	1400	1950	1400	1950
		6500	2850	7376	1974	1300	3	5	1300	1800	1300	1800
		7000	3070	7876	2194	1100	3	5	1100	1300	1100	1300

